

sample system for huge sized vessel

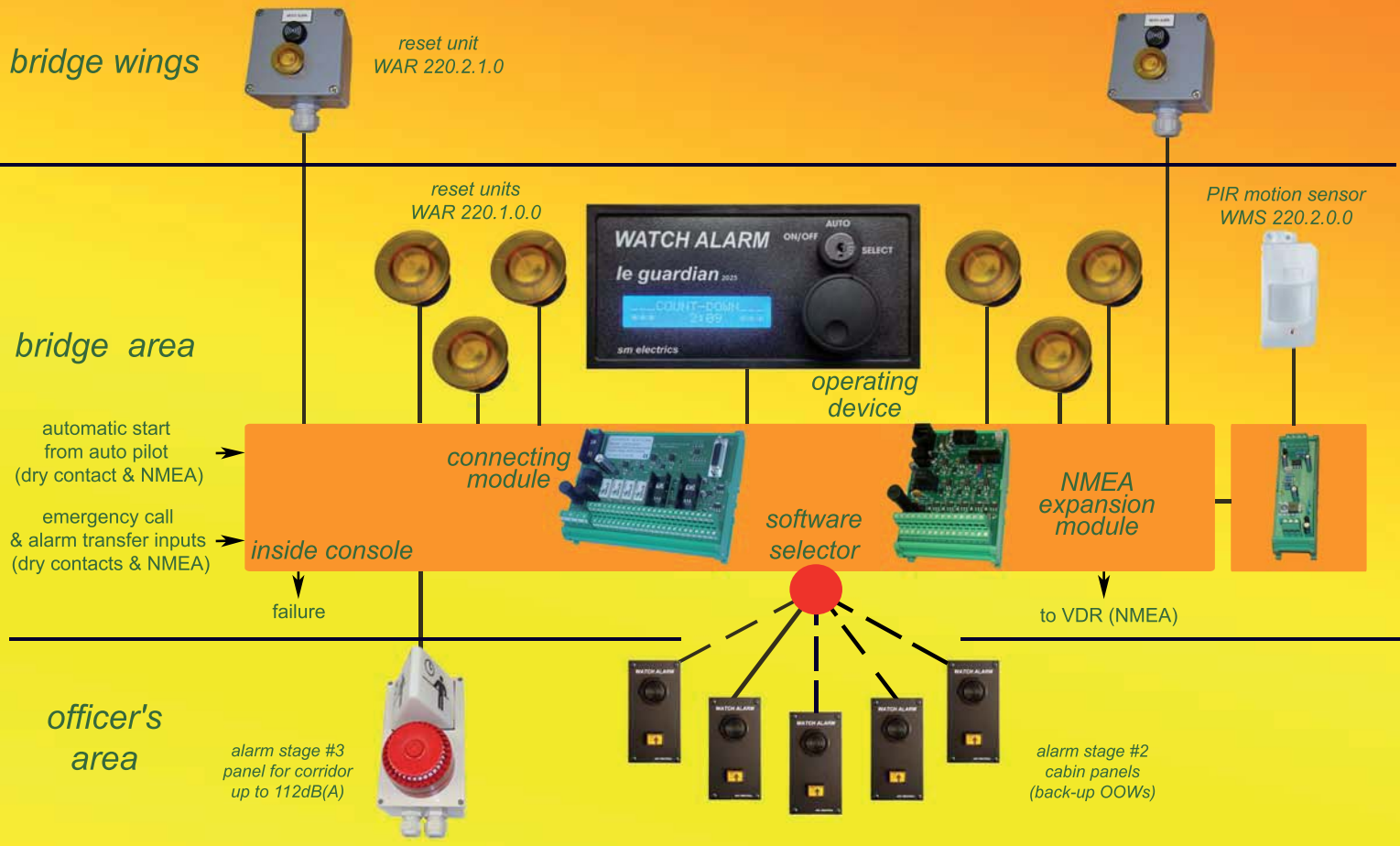

software selector switch for stage #2 alarm

- when key switch has been turned to position „SELECT“ a selection menu opens and Master decides which back-up OOW cabin receives stage #2 alarm. Multiple choice is possible!

12m 90° PIR motion sensor

- that sensor is supporting OOW by generating a count-down reset in case sensor detects a significant OOW movement.
- up to 4 sensors can operate parallel

sample system for medium sized vessel

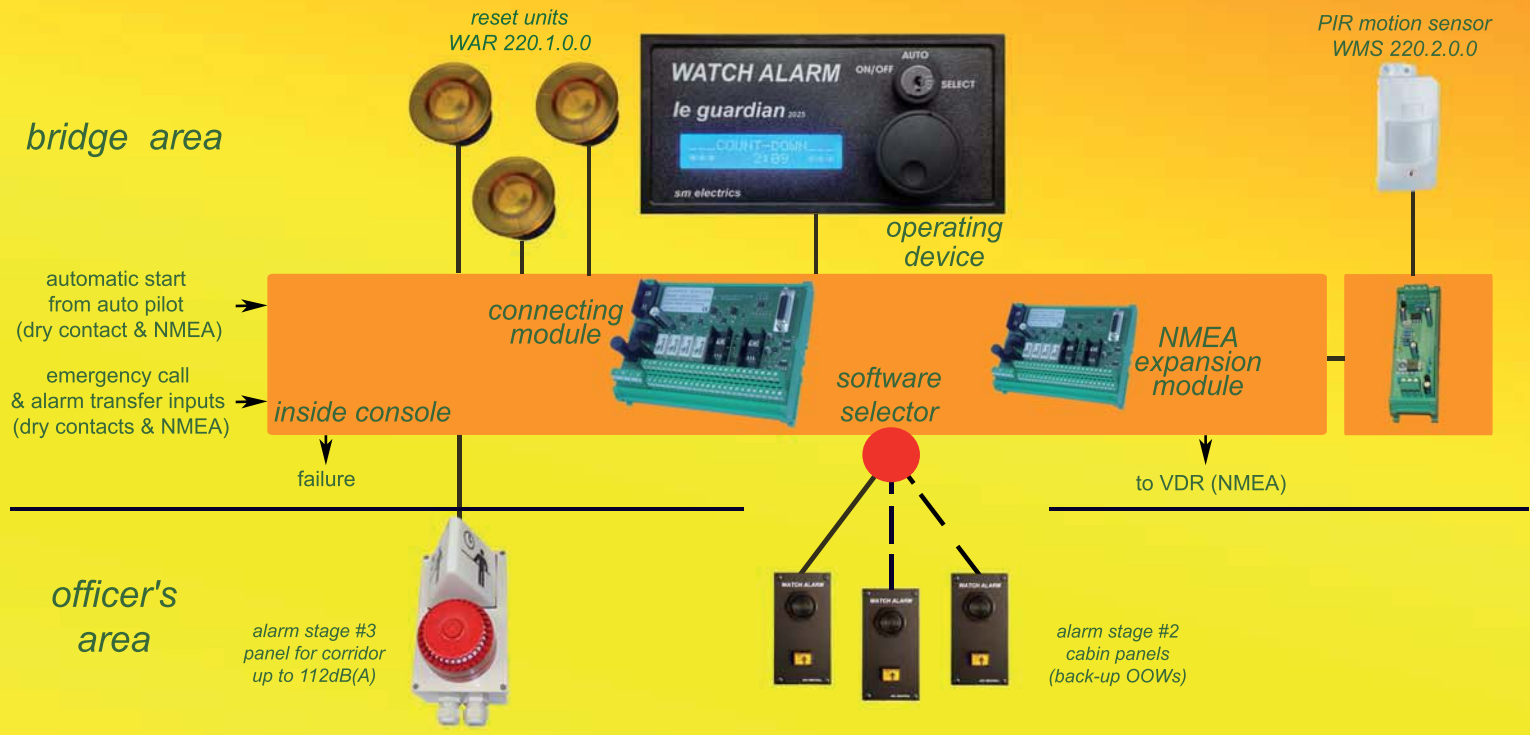

NMEA interface

- according to NMEA protocol IEC 61162-1 system sends all relevant operating states to NMEA receiver, especially VDR system.

emergency call facility & alarm transfer (unacknowledged alarms)

- clever logic allows to generate from each reset unit manually an emergency back-up OOW call
- 5 binary inputs (dry contacts expected) can be used to collect unacknowledged Nautical alarms transferring them to back-up OOW (time delay adjustable)

sample system for small sized vessel

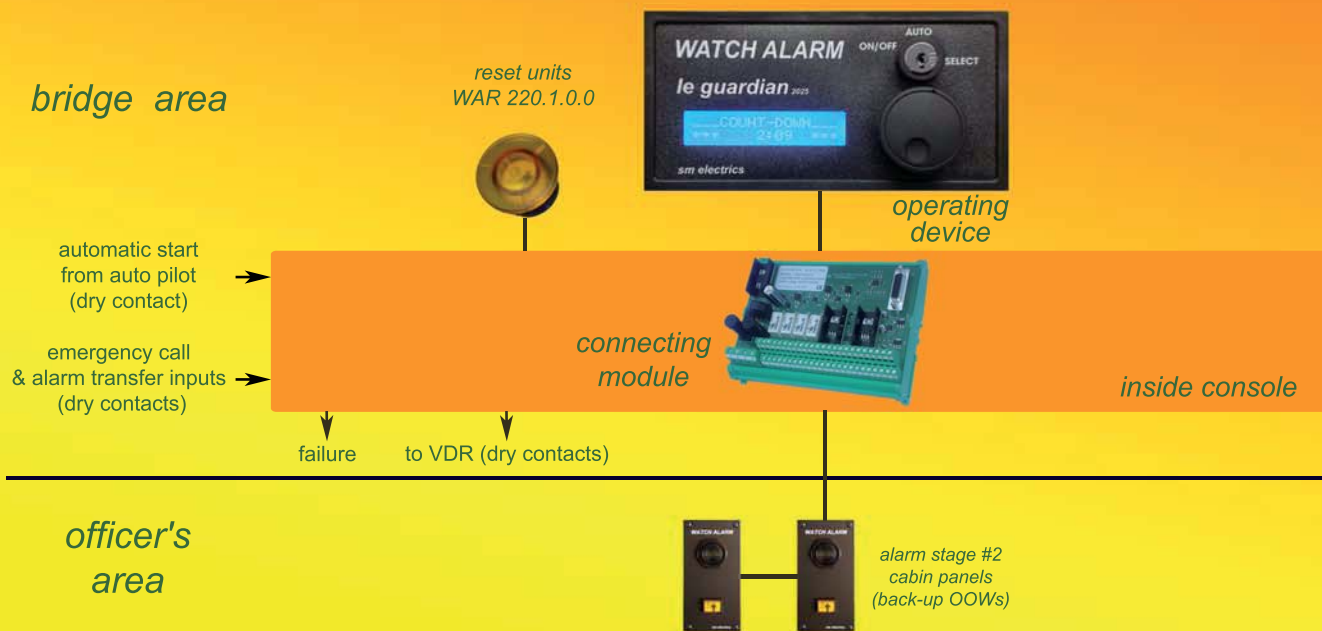

MSC 86 - legal background -

a bridge navigational watch alarm system (BNWAS) has to be installed as follows:

- ships of 150 gross tonnage and upwards and passenger ships irrespective of size constructed on or after 1 July 2011;
- passenger ships irrespective of size constructed 1 July 2011, not later than first survey after 1 July 2011;
- ships of 3,000 gross tonnage and upwards constructed before 1 July 2011, not later than the first survey after 1 July 2012;
- ships of 500 gross tonnage and upwards but less than 3,000 gross tonnage constructed before 1 July 2011, not later than the first survey after 1 July 2013
- ships of 150 gross tonnage and upwards but less than 500 gross tonnage constructed before 1 July 2011, not later than the first survey after 1 July 2014